

	特 性 FEATURES 120A 触点切换能力 120A Switching Capability 线圈与触点间耐压为 4KV 4KVDielectric Strength (Between Coil And Contact) 环保产品 (符合 RoHS) Environmental Friendly Product (RoHS Compliant) 可根据客户要求焊接附件 Accessories Can Be Customized 外形尺寸: (43.2×33.2×22) mm Dimensions: (43.2×33.2×22) mm
--	--

触点参数 CONTACT PARAMETERS

触点形式 Contact Form	1A、1B
触点材料 Contact Material	银合金 Silver Alloy
接触电阻 Contact Resistance	≤1mΩ (1A 6VDC)
触点负载 Contact Rating	120A 250VAC(阻性 Resistive)
最大切换电流 Max. Switching Current	120A(阻性 Resistive)
最大切换电压 Max. Switching Voltage	250VAC(阻性 Resistive)
最大切换功率 Max. Switching Power	30KVA
电气寿命 Electrical Life	1×10 ⁴ 次 OPS
机械寿命 Mechanical Life	1×10 ⁵ 次 OPS

性能参数 CHARACTERISTICS

绝缘电阻 Insulation Resistance	1000MΩ Min. (500VDC)	
介质耐压 Dielectric Strength	触点与线圈间 Between Coil & Contacts: 4000VAC 1min	
	断开触点间 Between Open Contacts: 2000VAC 1min	
动作时间 Operate Time	≤20ms	
复归时间 Release Time	≤20ms	
冲击 Shock Resistance	稳定性 Functional	98m/s ²
	强度 Destructive	980m/s ²
振动 Vibration Resistance	10Hz~55Hz 1.5mm 双振幅 (DA)	
湿度 Humidity	45%-90%RH	
温度范围 Ambient Temperature	-40°C~70°C	
引出端方式 Termination	快连接式 QC	
封装方式 Construction	防尘罩型 Dust Protected	
重量 Unit Weight	约 Approx.: 75g	

线圈规格表 COIL DATA(23°C)

额定电压 Rated Voltage VDC	动作/复归电压 Set/Reset Voltage VDC	脉冲宽度 Pulse Duration Ms	线圈电阻 Coil Resistance $\Omega \pm 10\%$		线圈功耗 Coil Power W
6	≤ 4.8	≥ 50	单线圈 Single Coil Latching	12	约 Approx. 3.0
9	≤ 7.2	≥ 50		27	
12	≤ 9.6	≥ 50		48	
24	≤ 19.2	≥ 50		192	
6	≤ 4.8	≥ 50	双线圈 Double Coils Latching	6/	约 Approx. 6.0
9	≤ 7.2	≥ 50		13.5/13.5	
12	≤ 9.6	≥ 50		24/24	
24	≤ 19.2	≥ 50		96/96	

订货标记示例 ORDERING INFORMATION

	MLM	-120	1	12	-A	-L1	-R	(XXX)
产品型号 Model:	MLM							
负载规格 Load:	120: 120A							
触点组数 Contact Group:	1:1 组 1 Group							
线圈电压 Coil Voltage:	06、09、12、24							
触点形式 Contact Form:	A: 常开 NO B: 常闭 NC							
线圈类型 Coil Type:	L1: 单线圈 Single Coil Latching L2: 双线圈 Double Coils Latching							
极性特点	R: 反极性 Negative Polarity (如接线图所示) 无: 标准极性 Positive Polarity (如接线图所示)							
特性号 Special Code	XXX: 客户特殊要求 Customer Special Requirement							

外形图、线圈接线图 OUTLINE DIMENSIONS、WIRING DIAGRAM

外形图 Outline Dimensions

单线圈 Single Coils

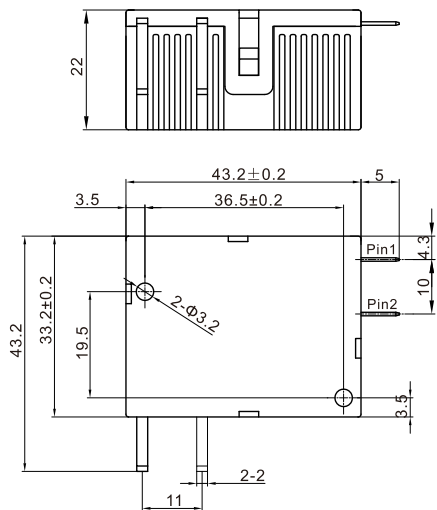

双线圈 Double Coils

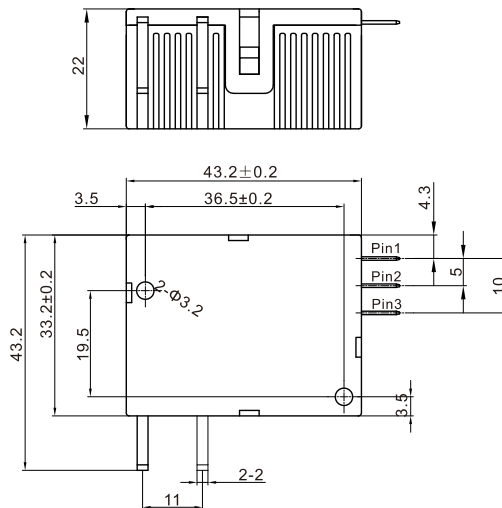

线圈接线图 Wiring Diagram

单线圈 Single Coils

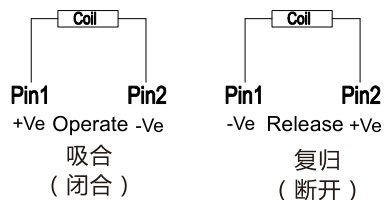
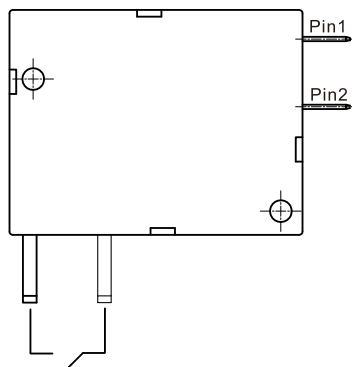

双线圈 Double Coils

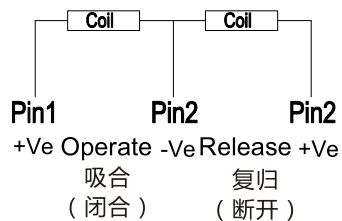
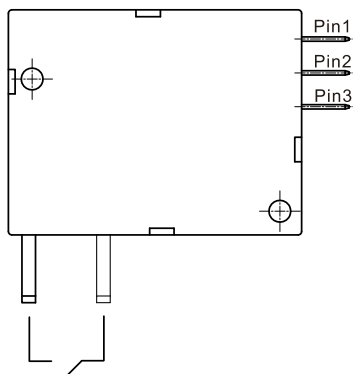

注意事项:

- 1、磁保持继电器出厂状态为动作或复归状态，但因运输或继电器安装时受到冲击等因素的影响，可能会改变状态，因而使用时（电源接入时）请根据需要重新将其设置为复归状态或动作状态；
- 2、为了确保磁保持继电器动作或复归，施加到线圈上的激励电压须达到额定电压，脉冲宽度须大于动作或复归时间的 5 倍；不要同时向动作线圈和复归线圈施加电压；不要长时间（大于 1 分钟）向线圈施加电压；
- 3、不带软铜绞线的磁保持继电器负载引出脚不能焊锡，不能随意扳动。
- 4、继电器通常为防尘罩结构，外接件按照客户特殊要求定制，所以推荐此产品的储存时间小于 6 个月，并注意仓储环境；同时为保证产品接触可靠性，在客户没有特别声明的情况下，我司将控制继电器触点为闭合状态。

NOTICE

1. Relay is on the "reset" or "set" status when being released from stock, with the consideration of shock risen from transit and relay mounting, relay would be changed to "reset" or "set" status, therefore, when application(connecting the power supply),please reset the relay to "reset" or "set" status on request.
2. In order to maintain "reset" or "set" status, energized voltage to coil should reach the rated voltage, impulse width should be 5 times more than "reset" or "set" time. Do not energize voltage to "reset" coil and "set" coil simultaneously. And also long energized time(more than 1min)should be avoided.
3. The terminals of relay without twisted copper wire can not be tin-soldered, can not be moved willfully, more over two terminals can' t be fixed at the same time.
4. Relays used for metering measuring applications are usually made with dust proof structure, while most relays could be made specially per customer' s specific requirements. No longer than 6 months' storage time is recommended for this kind of relay, and please pay attention to the storage environment. To ensure contact reliability, we will keep contact status be closed when delivery if no special required by customer.